

Mitigation of Damping Oscillation in Wind System Using TCR and TCSC

Seetharamudu Sirasala¹, Shiva Kumar M.², Rajasekar Reddy K.³

Abstract: With the worldwide growth of renewable energy, large wind farms are likely to be connected to series compensated networks for evacuation of bulk power. This may lead to the perturbations due to subsynchronous resonance (SSR) in the wind turbine generators. A detailed study using MATLAB/SIMULINK has been conducted in this paper to demonstrate that subsynchronous resonance can be a cause of concern in series compensated wind systems at realistic levels of series compensation. Two thyristor based FACTS devices i.e. a thyristor controlled reactor (TCR) and a thyristor controlled series capacitor (TCSC) are studied for mitigation of SSR under all realistic compensation levels in the doubly fed induction generator (DFIG) wind system. It is further realized with the help of simulation results that the performance of TCSC is superior to TCR for damping SSR.

Keywords: subsynchronous resonance; thyristor controlled reactor; thyristor controlled series capacitor.

1. INTRODUCTION

Wind power is a rapidly growing technology in the field of renewable energy. It is estimated that by 2030 wind power production of India may reach to 108.079 GW as that of world capacity of 1777.55 GW. With increase in power generation, there is a need to utilize the existing transmission lines effectively by transferring maximum possible power through it, keeping the power system in safe zone of operation. This is possible with the series compensation of lines i.e. reducing the reactance of line by using series capacitor. However use of series capacitors to improve the line loadability may cause subsynchronous oscillations which may damage the turbine-shaft system of the generator [1-3]. To protect the generator from these unwanted oscillations it is necessary to damp them [4]. These unwanted oscillations may also occur in series compensated wind system. Electromechanical oscillations between interconnected generators are the phenomenon inherent to power systems.

These oscillations can be associated with a single generator or a very closely connected group of units of a generating unit. The oscillations associated with a single generator or single plant is called local modes or plant modes. On the other hand the oscillations involving against group of generators are called inter-area oscillations. In this paper the local modes of oscillations are highlighted and the oscillations in the electromagnetic torque of doubly fed induction generator are damped out using thyristor controlled reactor (TCR) and thyristor controlled series capacitor (TCSC). In this paper simulation results obtained from the model based on MATLAB/SIMULINK are presented to validate the effectiveness of the TCR and TCSC in damping subsynchronous resonance.

2. SUBSYNCHRONOUS RESONANCE

Turbine generators have rotating shaft systems comprised of large internal masses that are interconnected with shafts that act as springs. These large masses and shafts create torsional resonant frequencies some of which are also subsynchronous. If the transmission line frequency is close to the complimentary mechanical system frequency of the generating machine, then these two systems interact with each other. In some operating conditions, the interactions can result in damaging shaft torques on a turbine-generator shaft. This interaction is called as subsynchronous resonance and briefly explained as an electric power system condition where the electric network exchanges energy with the turbine-generator at or more of the natural frequencies of the combined system below the synchronous frequency of the system [3].

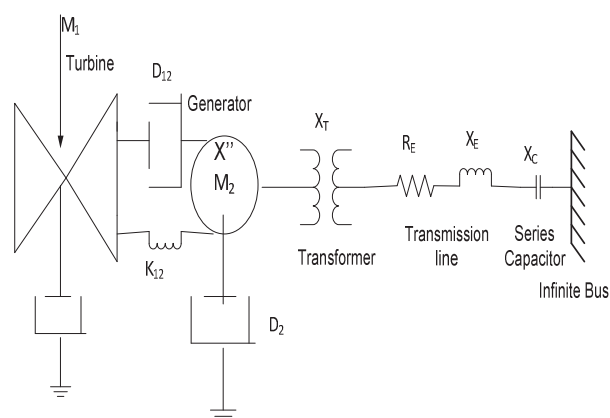

Fig.1 Turbine-generator with series compensation transmission line.

The series resonant frequency f_c is as given in (1).

$$f_e = f_o \sqrt{\frac{X_c}{X_\Sigma}} = f_o \sqrt{\frac{X_c}{X_E + X_s}} = \frac{f_o}{\sqrt{\frac{X_E + X_s}{kX_E}}} = \frac{f_o}{\sqrt{\frac{1}{k} + \frac{X_s}{kX_E}}} \quad (1)$$

Where

X_s = reactance of generator and transformer (p.u.)

X_E = line reactance (p.u.)

X_c = reactance of series capacitor (p.u.)

X_Σ = total system reactance (p.u.) = $X_T + X_E$

k = degree of series compensation = X_c/X_E

f_o = nominal system frequency (Hz)

$f_e < f_o$ since $k < 1$

3. THYRISTOR BASED FACTS DEVICES:

A. Thyristor controlled reactor

The thyristor controlled reactor (TCR) consists of a series reactor and a bidirectional thyristor valve. The TCR is regularly used in conjunction with fixed or thyristor-switched capacitors to provide rapid, continuous control of inductive reactance so that it controls the reactive power in the line during lagging period. Reference voltage is compared with the system voltage and this error signal is processed through the voltage regulator block, which of PI controller whose constants are selected so that it can provide the rapid and continuous control of the inductive reactance. TCR controller block diagram is shown in Fig.2 [5].

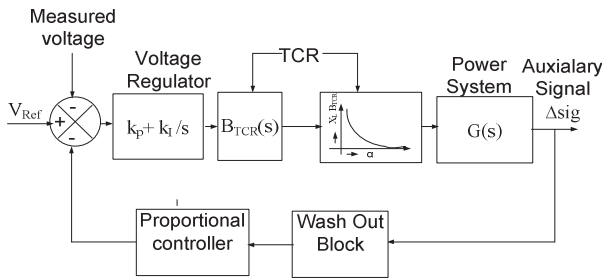

Fig. 2. TCR control circuit

The susceptance block and power system block gives an auxiliary signal which is used as damping controller. The firing angle for the TCR's anti-parallel thyristors is selected in accordance with the power system susceptance value.

B. Thyristor Controlled Series Capacitor

The TCSC increases the power transfer capability of a transmission network. It provides a rapid, continuous control of the transmission-line series compensation level thus dynamically controlling the power flow in the line. The TCSC

is assumed to be primarily employed in the network for controlling line reactance and thereby the power flow. The SSR damping function is added through constant current control technique. The TCSC operating at fundamental frequency offers a pure capacitive reactance to increase the power transfer capability of the network. On the other hand, the same TCSC offers resistive and inductive impedance at subsynchronous frequencies which assists in damping subsynchronous modes [6]. The resistive impedance of the TCSC increases with the increased boost factor given which is the ratio of the capacitive reactance offered by the TCSC and the total line reactance as given in (2).

$$k = \sqrt{\frac{X_c}{X_s}} \quad (2)$$

$$X_{TCSC} = \frac{V_{CF}}{I_m} = X_c - \frac{X_c^2}{X_c - X_L} \frac{2\beta + \sin 2\beta}{\pi} + \frac{4X_c^2}{X_c - X_L} \frac{\cos^2 \beta (k \tan \beta - \tan \beta)}{k^2 - 1} \frac{1}{\pi} \quad (3)$$

The equivalent TCSC reactance is computed as per the (3).

$$\alpha_{res} = \pi - (2m - 1) \frac{n\omega}{2\omega_r}; m = 1, 2 \quad (4)$$

Where β is the angle of advance (before the forward voltage becomes zero) = $\pi - \alpha$; and α is the firing angle of the thyristors. It is noted from (3), that a parallel resonance is created between X_c and X_L at the fundamental frequency. Corresponding to the values of firing angle α_{res} , is given by (4).

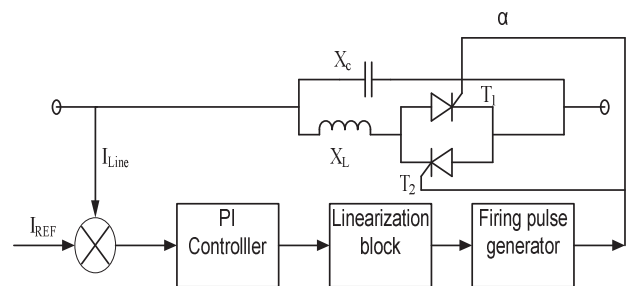

Fig.3 TCSC current controller circuit

In the TCSC controller circuit the pre fault or pre contingency current is compared with the fault current of the power system. The error thus obtained is processed through PI controller and linearization block. Finally the error control signal is given to firing pulse generator which generates the required pulses for the triggering of anti-parallel thyristors in TCSC [7].

4. WIND SYSTEM CONFIGURATION

Fig.4 shows the model of wind turbine generator with series compensation without using any FACTS devices. The double fed induction generator considered in the model is of 9 MW rating with generating voltage at 440 V and at 50 Hz frequency. The voltage from the induction generator has stepped up to 33 KV using a step up transformer of 3-phase, 50 Hz, 440 V/33 KV, 15 MVA, star/delta connection, and connected through a transmission line of pi section type. It is transmitted through a distance of 60 km with series compensation. At the end of the grid the voltage is again stepped up to 132 KV and supplied to the grid using a transformer of 3-phase, 50 Hz, 132 KV/33 KV, 60 MVA delta/star connections.

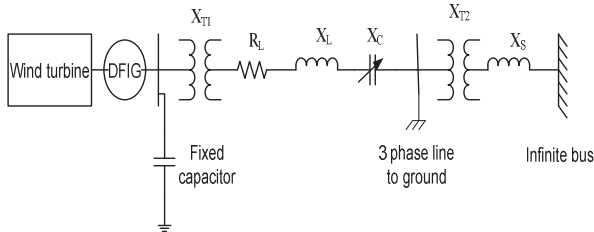

Fig. 4. Model of wind turbine generator with series compensation.

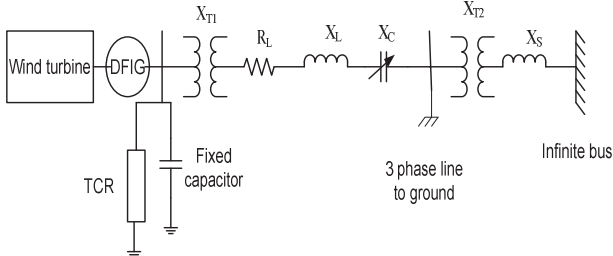

Fig. 5. Model of wind turbine generator with series compensation and shunt connected TCR

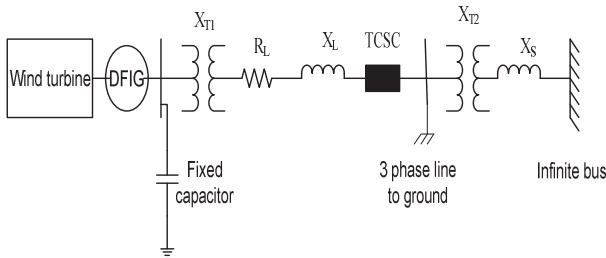

Fig. 6. Model of wind turbine generator series compensation with series connected TCSC

In this paper first the analysis is done for the system with series compensation but with no FACTS devices later on the analysis is extended along with TCR and TCSC for a three phase to ground fault for duration of 0.12 to 0.15 sec. The

wind systems along with TCR and TCSC are shown in Fig.5 and 6 respectively.

5. RESULTS

A. Series Compensation of Wind System without Thyristor Based FACTS Devices:

Fig.7 (a) to (e) shows the variations in the electromagnetic torque of the doubly fed induction generator at 40%, 50%, 60%, 70% and 80% respectively without connecting any thyristor based FACTS devices for compensation.

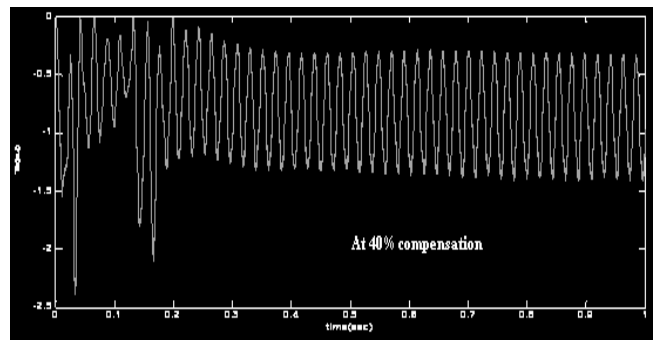

(a)

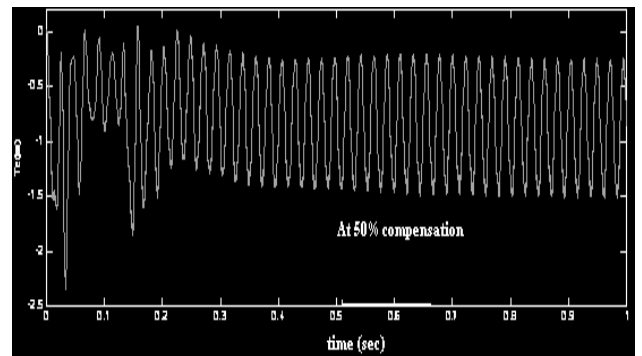

(b)

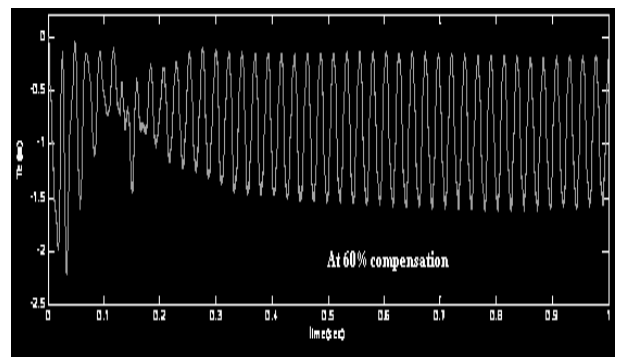

(c)

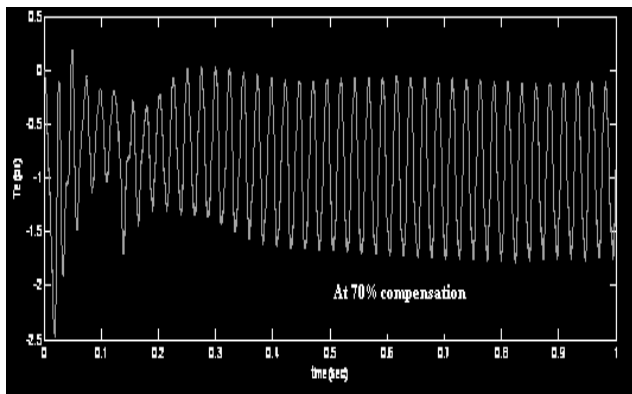

(d)

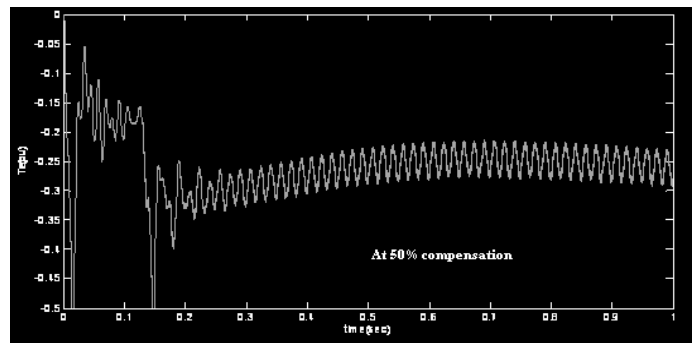

(b)

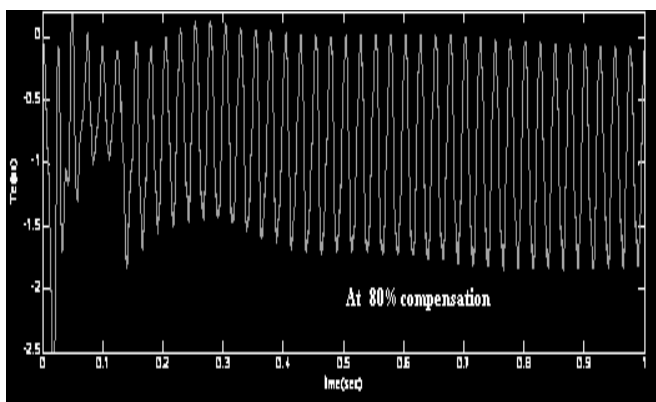

(e)

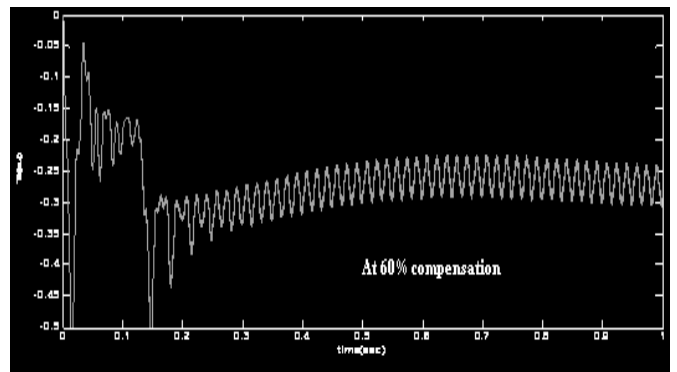

(c)

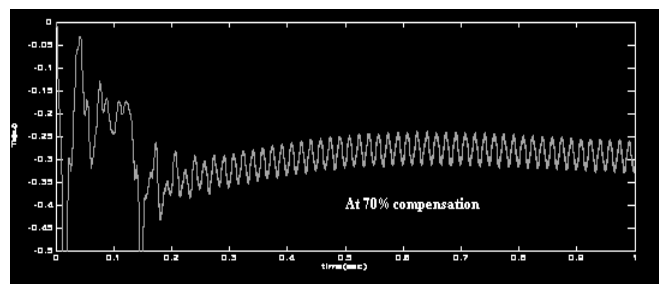

(d)

Fig.7 (a) to (e) Variations in electromagnetic torque at different compensation levels without thyristor based FACTS devices

Wind System Series Compensation with Shunt Connected TCR:

Fig.8 (a) to (e) shows the variations in the electromagnetic torque of the doubly fed induction generator at 40%, 50%, 60%, 70% and 80% respectively with shunt connected TCR.

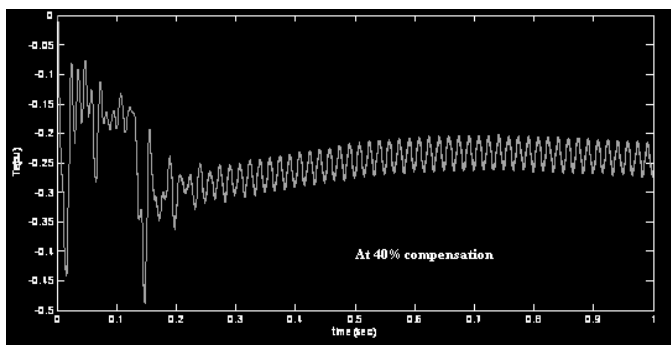

(a)

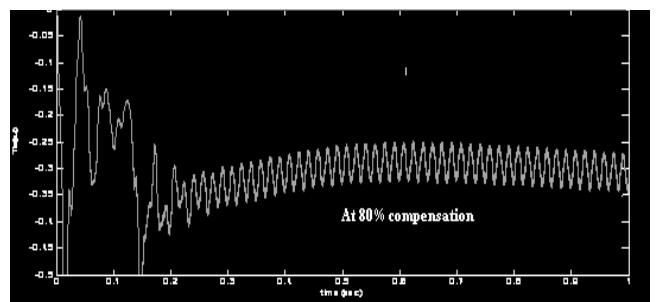

(e)

Fig.8 (a) to (e) Variations in electromagnetic torque at different compensation levels with shunt connected TCR

C. Wind System Series Compensation with Series Connected TCSC:

Fig.9 (a) to (e) shows the variations in the electromagnetic torque of the doubly fed induction generator at 40%, 50%, 60%, 70% and 80% respectively with series connected TCSC.

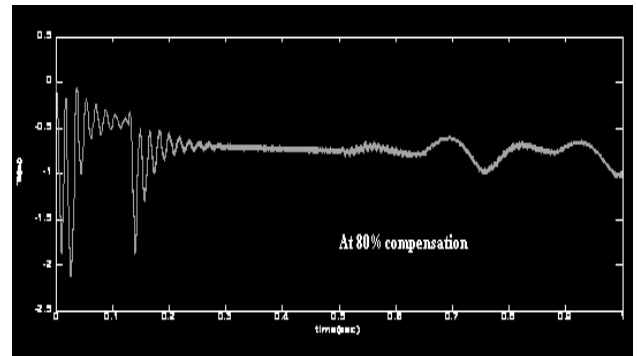
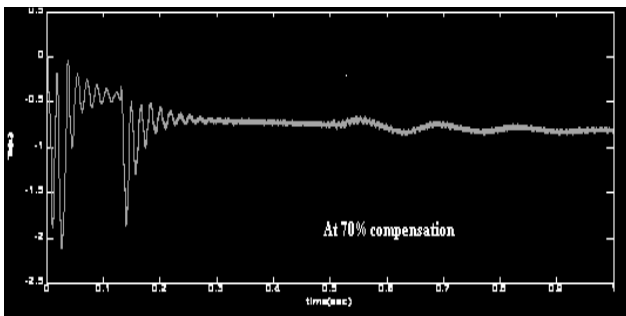
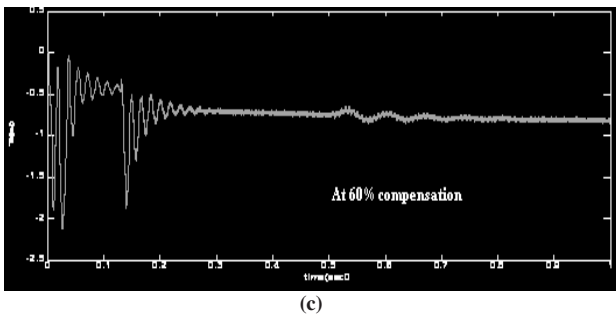
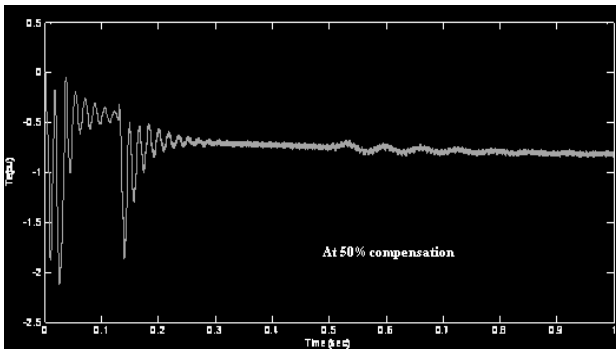
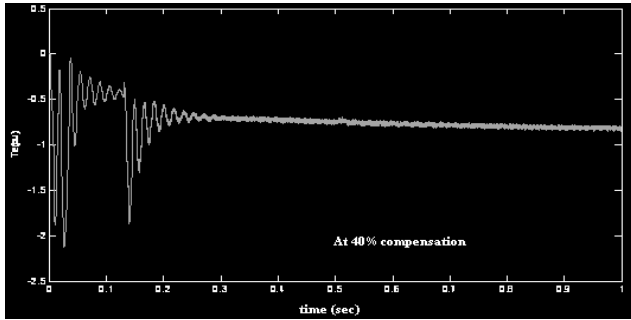
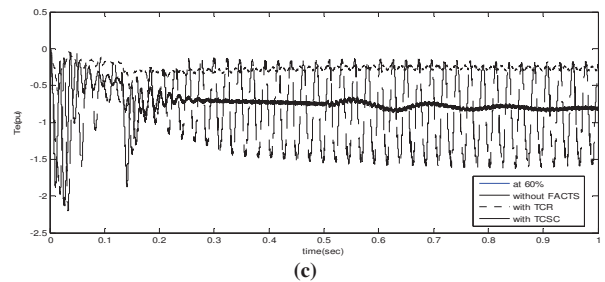
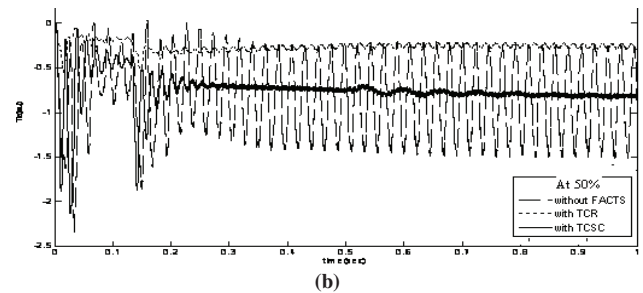
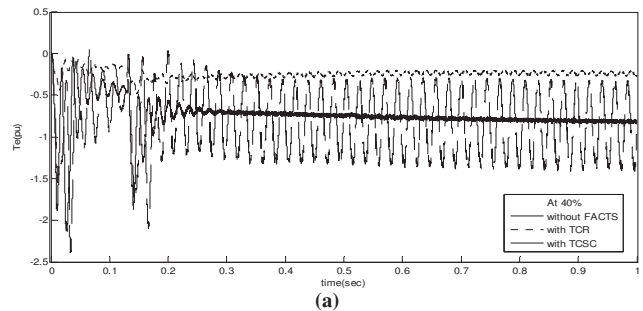

Fig.9 (a) to (e) Variations in electromagnetic torque at different compensation levels with series connected TCSC

D. Comparison between electromagnetic torque variations with and without FACTS devices:

Fig.10 (a) to (e) shows the variations in electromagnetic torque of DFIG for different compensation levels with and without FACTS devices i.e TCR and TCSC.



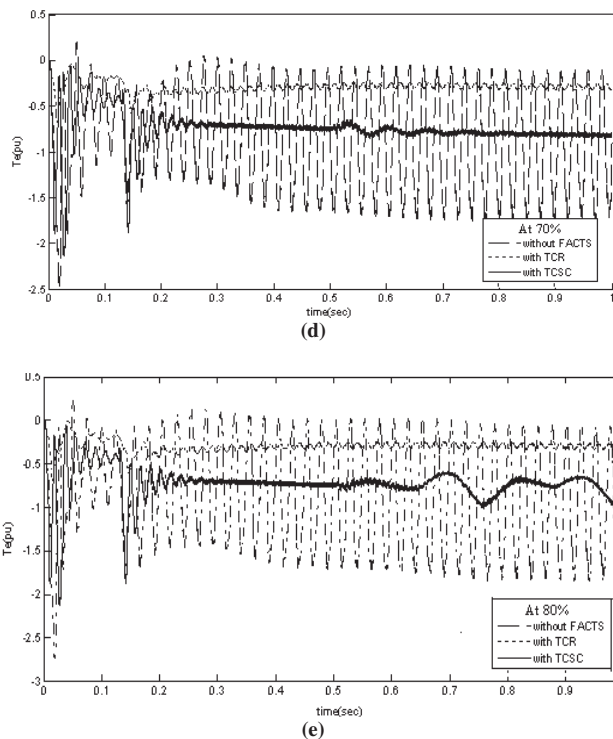

Fig.10 (a) to (e) Variations in electromagnetic torque at different compensation levels with and without FACTS devices

6. CONCLUSION

Owing to the increase of wind power penetration into power system grid, wind farms are likely to be evacuating bulk power through series compensated networks. This will make the power system vulnerable to SSR. In this paper two thyristor based FACTS devices (i.e. TCR and TCSC) are applied to damp SSR in series compensated wind farm. The following conclusions are drawn from simulation results

obtained from MATLAB/SIMULINK over widely varying levels of series compensation applied.

- As the level of series compensation goes on increasing the electromagnetic oscillation also increases.
- TCR and TCSC both are effective in damping SSR. However this paper highlights the superiority of TCSC over TCR in mitigating SSR problem in power systems. Further the paper can serve the researchers in exploring the application of TCSC for other problems in power systems.

7. REFERENCES

- [1] P. Kundur, "Power System Stability and Control". McGraw-Hill, New York, 1993.
- [2] M. Klein, G. J. Rogers and P. Kundur, "A Fundamental Study of Interarea Oscillations in Power Systems", IEEE Trans. on Power Syst. vol.6, no.3, pp.914-921, Aug.1991.
- [3] IEEE Working Committee Report, "Third Supplement to a Bibliography for the Study of Subsynchronous Resonance between Rotating Machines and Power Systems", IEEE Trans. on Power Systems, vol. 6, no. 2, pp. 830-834, May 1991.
- [4] E. W. Kimbark, "Improvement of System Stability by Switched Series Capacitors", IEEE Transactions on Power Apparatus and Systems", vol. 85, pp. 180-188. Feb.1999.
- [5] R. K. Varma and S. Auddy, "Mitigation of Subsynchronous oscillations in a Series Compensated Wind Farm using Static VAR Compensator," in Proc. IEEE Power Eng. Soc. General Meeting Conf., pp. 1-7, 2006.
- [6] E. V. Larsen, K. Clark, S. A. Miske Jr., and J. Urbanek, "Characteristics and Rating Considerations of Thyristor-Controller Series Compensation," IEEE Transactions on Power Delivery, vol. 9, no. 2, pp. 992-1000, April 1994.
- [7] R. K. Varma, S. Auddy and Ysni Semsedini, "Mitigation of Subsynchronous resonance in a series compensated wind farm using FACTS Controllers", IEEE Transactions on Power Delivery, vol. 23, no. 3, pp.1645-1654, July 2008.

¹Seetharamudu Sirasala Obtained B.Tech degree in JNTU University Hyderabad, India and M.tech (Control systems) degree from National Institute of Technology (NIT) kurukshetra India. Currently working as Assistant professor in Santhi Ram Engineering College, NH-18, Nandyal, Kurnool (D.T) Andhra Pradesh, India- 518501. mail id: s.ramudu46@gmail.com.

²Shiva Kumar. M.S Obtained B.tech degree from JNTU University Anathapur, India. Prior worked as project trainer. Currently working as a Assistant professor in Santhi Ram Engineering College, NH-18, Nandyal, Kurnool (D.T) Andhra Pradesh, India- 518501. mail Id: machani.shiva02@gmail.com.

³Rajasekhar Reddy.K, Obtained B.tech degree from G.Pulla Reddy Engineering College, and Master degree in Power Electronic from JNTU University Hyderabad, India. Currently working as Associate professor in Santhi Ram Engineering College (SREC), NH-18, Nandyal, Kurnool (D.T) Andhra Pradesh, India- 518501. mailId:raju.gprec@gmail.com.